

THIS DRAWING IS UNPUBLISHED. RELEASED FOR PUBLICATION ,19 .
 © COPYRIGHT 19 BY AMP INCORPORATED. ALL RIGHTS RESERVED.

LOC	DIST	REVISIONS				
P	LTR	DESCRIPTION	DATE	DWN	APVD	
G	14	J	REVISED & REDRAWN PER 0L20-0086-96	28OCT96	DKS	DMS

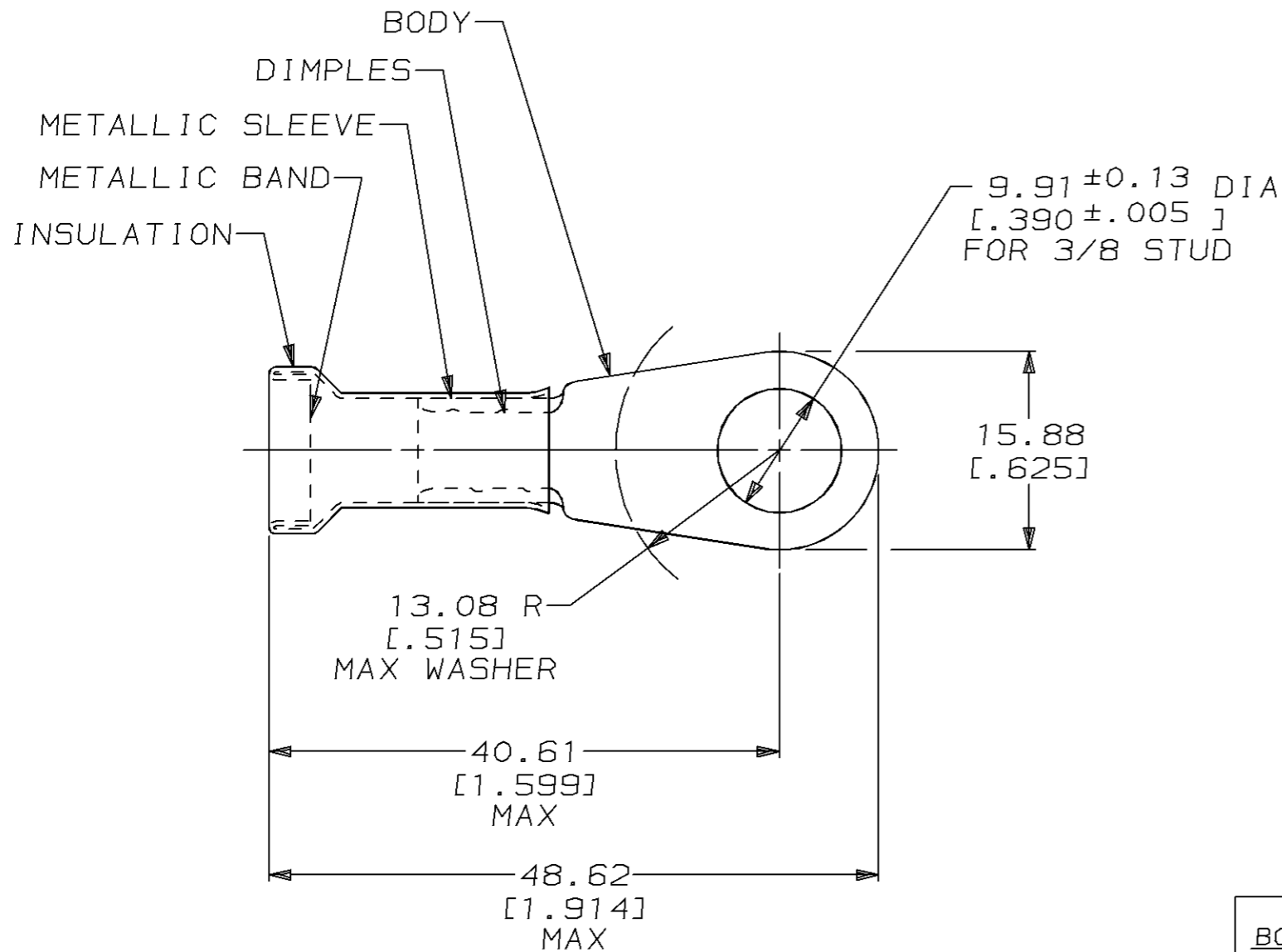

- ① TIN PL 0.00254 [.000100] MIN THK PER MIL-T-10727
- ② GOLD PL 0.00127 [.000050] MIN EXT THK PER MIL-G-45204 OVER NICKEL PL 0.00762 [.000030] MIN EXT THK PER QQ-N-290
- ③ TAPE MOUNTED
- 4 WIRE INSULATION: 9.58 [.377] MAX DIA
- 5 MATERIAL THK: 1.14 ± 0.08 [.045 ± .003]

<u>BODY:</u> COPPER PER ASTM B-152 ANNEALED	③ 2-322007-2 ①
<u>INSULATION:</u> PVC <u>COLOR:</u> BLUE	
<u>METALLIC SLEEVE:</u> COPPER PER ASTM B-152 ANNEALED	2-322007-1 ②
<u>METALLIC BAND:</u> STEEL PER ASTM A-109	
TIN PL 0.00254 [.000100] MIN THK PER MIL-T-10727	322007 ①
MATERIAL & FINISH	AMP PART NUMBER

AMP INCORPORATED
CUSTOMER SERVICE SYSTEMS

FOR ADDITIONAL PRODUCT INFORMATION OR COPIES OF DRAWINGS AND TECHNICAL DOCUMENTS	PRODUCT INFORMATION CENTER 1-800-522-6752	RECOMMENDED OPERATING TEMPERATURE: 105°C MAX
FOR APPLICATION TOOLING INFORMATION	TOOLING ASSISTANCE CENTER 1-800-722-1111	VOLTAGE RATING: NOT APPLICABLE
FOR ORDER ENTRY	1-800-526-5142	WIRE CROSS SECTIONAL AREA RANGE: 10.5-16.8mm ² [20,800-33,100] CIR MILS SOLID OR STRANDED

THIS DRAWING IS A CONTROLLED DOCUMENT.		DWN DK SCHRUM 28OCT96	AMP Incorporated Harrisburg, PA 17105-3608
DIMENSIONS: mm [INCHES]	TOLERANCES UNLESS OTHERWISE SPECIFIED:	CHK DM SWARTZ 29OCT96	
	0 PLC ±-	APVD JL MECKLEY 29OCT96	
	1 PLC ±-	PRODUCT SPEC	
MATERIAL	FINISH	APPLICATION SPEC	NAME TERMINAL ASSEMBLY, RING TONGUE, AMPLI-BOND™, WIRE SIZE: 6 AWG
SEE TABLE	SEE TABLE	WEIGHT	SIZE A3
		CUSTOMER DRAWING	CAGE CODE 00779
			DRAWING NO C-322007
			SCALE 2:1
			SHEET 1 OF 1
			REV J